



WORKSHOP MANUAL

for D14/4 models

BANTAM SUPREME

BANTAM SPORTS

BUSHMAN

**Service Department
B.S.A. MOTOR CYCLES LTD.**

BIRMINGHAM 11

**Telephone 021-772 2381
ARMOURY ROAD**

Please Note!

Replacement parts or accessories must be of B.S.A. origin or as approved by B.S.A Motor Cycles Ltd.

In this respect your attention is drawn to the Terms and Conditions of B.S.A. Guarantee.

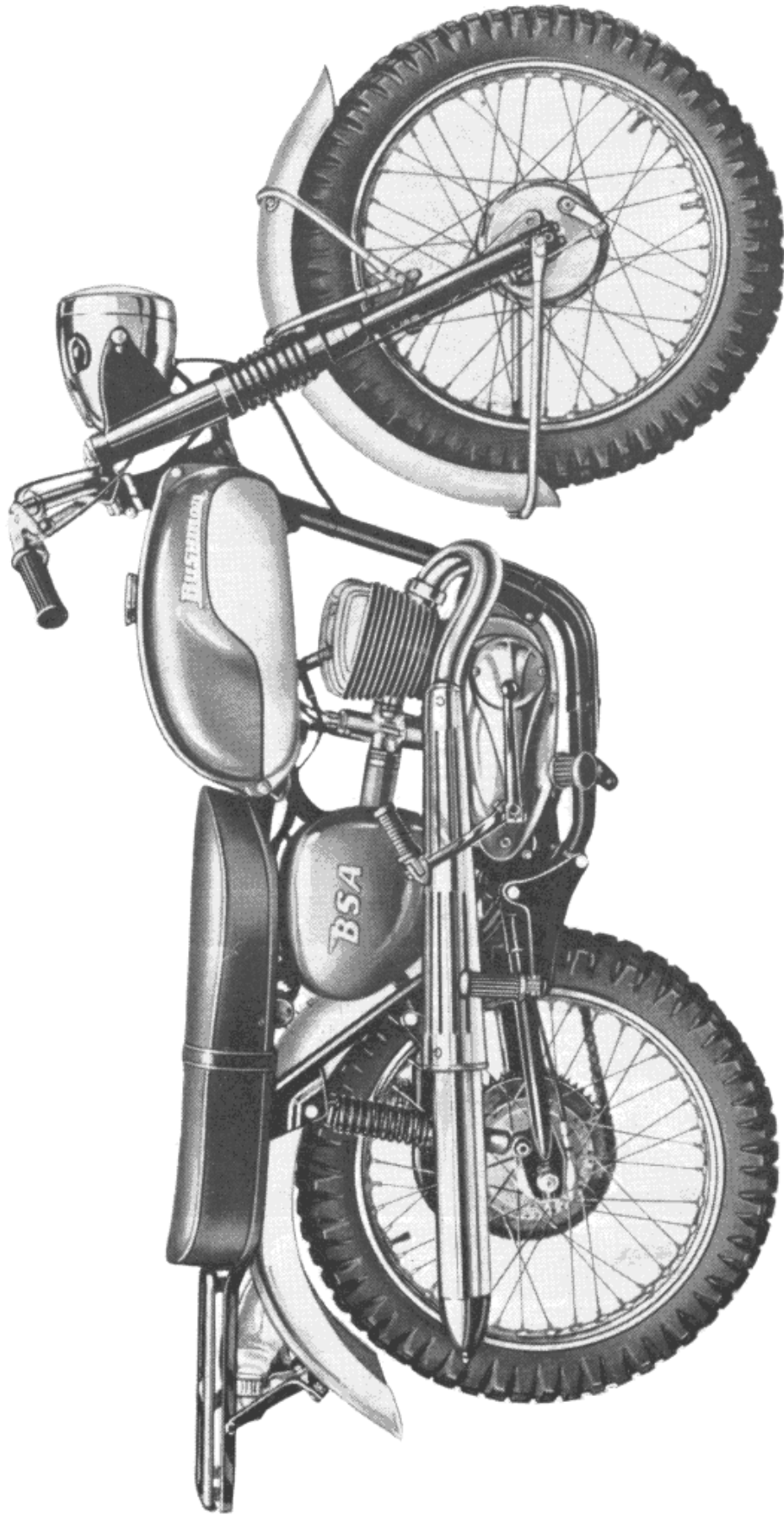

BSA DI4 175 c.c. BUSHMAN

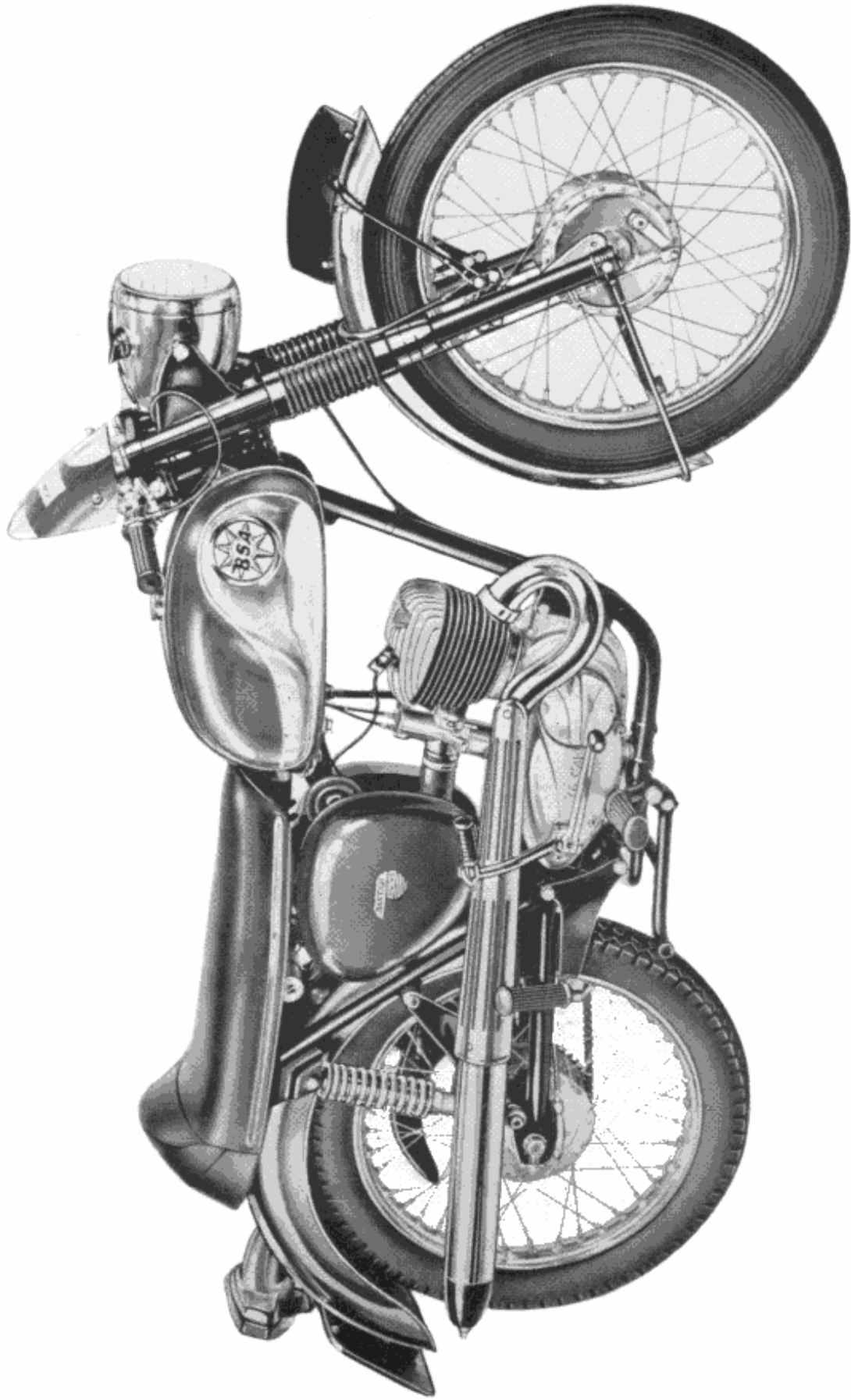

BSA 175 c.c. BANTAM SPORTS (SPORTSMAN U.S.A.)

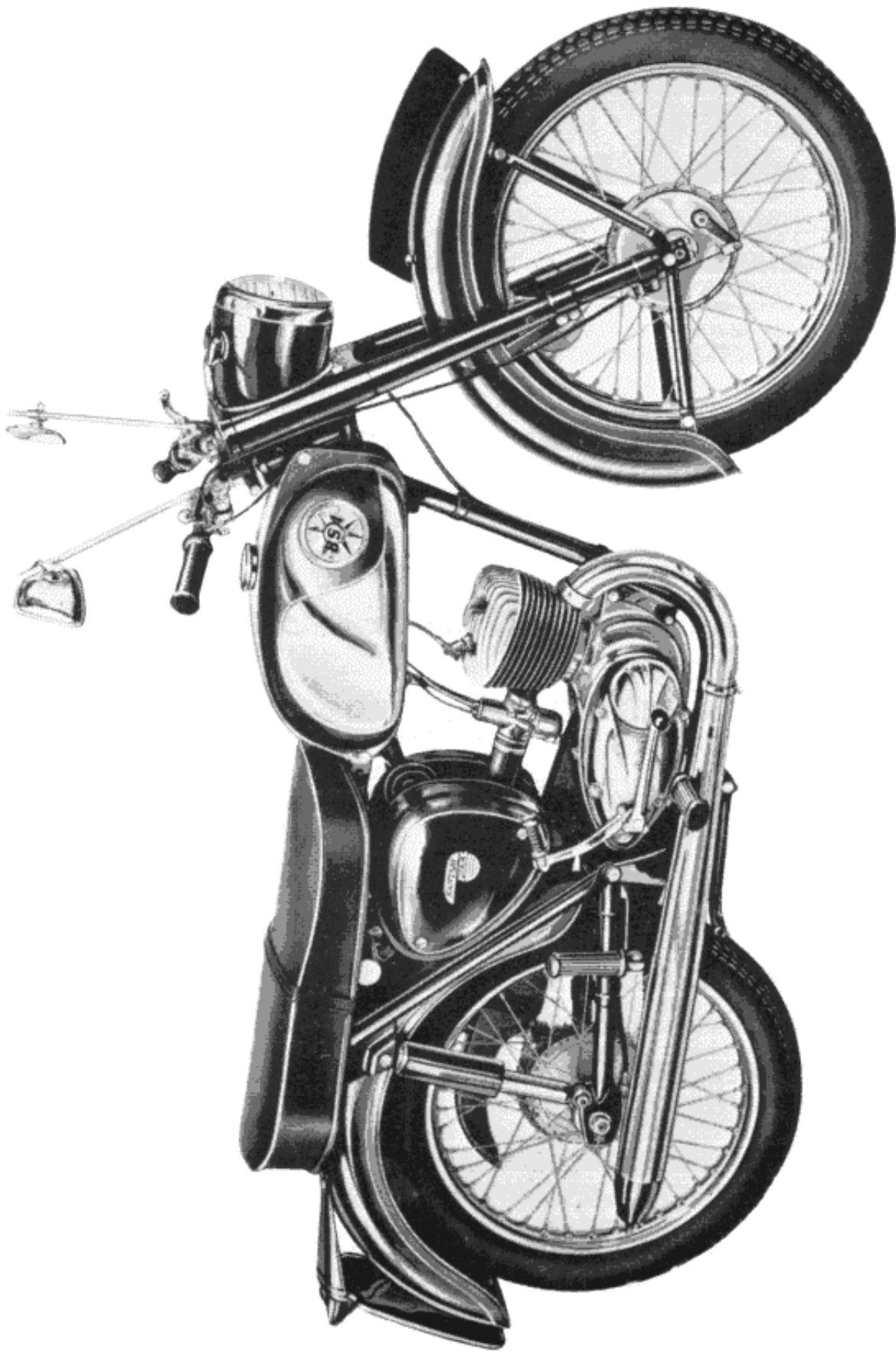

BSA 175 c.c. BANTAM SUPREME

INTRODUCTION

The object of this manual is to provide comprehensive service information for both the B.S.A. owner, and the workshop fitter, wishing to carry out either basic maintenance or major repair work. As some of the repair work described requires specialised skills and workshop equipment, the inexperienced owner is strongly advised to consult his B.S.A. dealer should he doubt his own ability to carry out a satisfactory job.

This manual is divided into sections, each dealing with a major assembly, and these are sub-divided into the individual operations required for maintenance or repair. It is hoped that by using this arrangement not only will the manual be useful to the inexperienced mechanic, but it will also serve as a reference book for the skilled mechanic.

The information given in this manual is correct at the time of publication, but in the course of constant development it is inevitable that there will be changes in specification. Anyone finding the information given in this manual to be at variance with the machine in his possession is advised to contact the B.S.A. Motor Cycles Service Department, where up-to-date information will be provided.

ENGINE AND FRAME NUMBERS

Both the engine and frame numbers, together with prefix and suffix letters, must be quoted in full on any correspondence relating to the machine or on any enquiry regarding this manual.

The engine number is stamped on top of the crankcase immediately below the cylinder. The frame number is stamped on the front engine mounting plate.

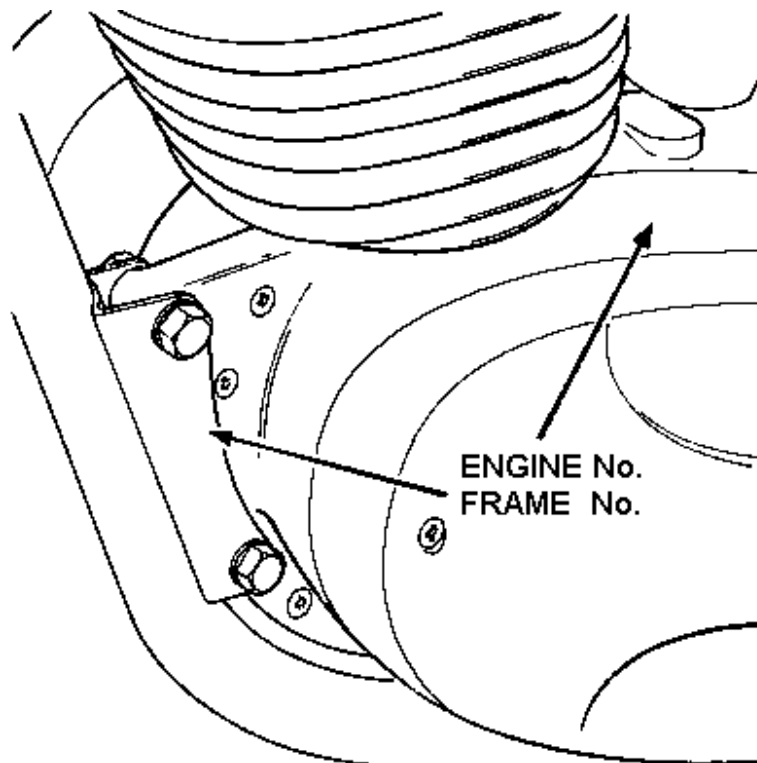

Factory Service Arrangements

(UNITED KINGDOM)

REPLACEMENT PARTS

B.S.A. replacement parts are distributed through a national network of B.S.A. dealers, each of whom holds a stock of fast moving parts. Approximately 200 of these dealers have been selected for appointment as specialist B.S.A. replacement part stockists and each of these stockists holds a comprehensive stock of B.S.A. replacements. List of appointed stockists are available on request, and their names are printed in every B.S.A. parts catalogue.

GUARANTEE CLAIMS

In the interests of all concerned it is best that any owner of a new motor-cycle wishing to claim assistance under the guarantee should do so through the dealer from whom his machine was purchased. All B.S.A. dealers are familiar with the procedure designed by B.S.A. to give quick service to any owner of a B.S.A. motor-cycle who may find himself in difficulty.

REPAIRS

Most appointed B.S.A. dealers are able to carry out major repair work, and owners are asked to make all repair arrangements through their chosen dealer.

In the great majority of cases local repair will be possible and this will avoid unnecessary expense and inconvenience, and the possibility of the machine being damaged in transit to or from the works for repair.

Should your B.S.A. dealer decide that Service Department attention is required he will know best how to make suitable arrangements with the factory. It is important to remember that no machine can be accepted at the works without a prior appointment. This appointment can be made either by letter or telephone.

Labour time will be greatly reduced if proprietary articles such as legshields, safety bars, carriers or fibre-glass fairings are removed before handing the machine over for repair. Accessories such as mirrors or badges should always be removed before entrusting a machine to an independent carrier.

Where parts such as cylinders, petrol tanks etc., are forwarded for repair, they should be packed securely so as to avoid damage in transit.

All parts sent to the Service Department for repair should be clearly labelled with the owners name and address, and should have attached a label giving full instructions.

TECHNICAL ADVICE

B.S.A. Service Department staff have long experience in dealing with technical problems of all kinds and will be pleased to help in the event of difficulty. The correct address of the service department is as follows:—

B.S.A. MOTOR CYCLES LIMITED,
SERVICE DEPARTMENT,
ARMOURY ROAD,
BIRMINGHAM 11.
Telephone No. 021-772 2381

In all communications the model must be quoted with full engine and frame numbers together with all prefix or suffix letters.

SERVICE ARRANGEMENT OVERSEAS

In most markets of the world B.S.A. has an appointed distributor to whom all service enquires should be addressed.

PROPRIETARY PARTS

Equipment not of our manufacture, fitted to our motor-cycles, is of the highest quality and is guaranteed by the manufacturers and not by us. Any complaints or repairs should be sent to the manufacturer concerned or their accredited agents who will give every possible assistance. The following are the manufacturers concerned:—

CARBURETTERS	Amal Limited, Holdford Road, Witton, BIRMINGHAM 6.
CHAINS	Renold Chains Limited, Wythenshawe, MANCHESTER.
ELECTRICAL EQUIPMENT	Wipac Group Sales Limited, London Road, BUCKINGHAM. Joseph Lucas Limited, Gt. Hampton Street, BIRMINGHAM 18.
REAR DAMPERS	Girling Limited, Birmingham Road, WEST BROMWICH, Staffs.
SPARK PLUGS	Champion Sparking Plug Co. Ltd., Feltham, MIDDLESEX.
SPEEDOMETERS	Smith's Motor Accessories Limited, Cricklewood Works, LONDON N.W.2.
TYRES	Dunlop Company Limited, Fort Dunlop, BIRMINGHAM 24.

U.S.A. SERVICE ARRANGEMENT

REPLACEMENT PARTS

B.S.A. replacement parts are available through a national network of B.S.A. dealers covering the entire United States.

These B.S.A. motor-cycle dealers are listed under "Motorcycles" in the yellow pages of your local telephone directory.

All requests for parts must be made through franchised B.S.A. dealers, they are not sold directly to B.S.A. by the two factory branches.

GUARANTEE CLAIMS

In the interest of all concerned the owner of a new motor-cycle wishing to claim assistance under the guarantee must do so through the dealer from whom his machine was purchased.

REPAIRS

B.S.A. dealers are capable of servicing and repairing B.S.A. motor-cycles, ask your dealer to help when repairs are needed.

Labour time will be greatly reduced if proprietary articles, such as legshields, crash bars, carriers or fibre-glass fairings, are removed before handing the machine over for repair. Accessories, such as mirrors or badges, should always be removed before entrusting a machine to an independent carrier.

TECHNICAL ADVICE

The B.S.A. Service Department staff at the two U.S.A. factory branches are experienced in dealing with technical questions of all kinds and will be pleased to help in the event of difficulty.

The factory branch addresses are shown below:—

EASTERN: **B.S.A. INCORPORATED,**
639 Passaic Avenue,
Nutley,
NEW JERSEY 07110

WESTERN: **B.S.A. MOTORCYCLES—WESTERN,**
2745 E. Huntington Drive,
Duarte,
CALIFORNIA 91010

In all communications the full engine and frame numbers with all prefix and suffix letters and figures must be quoted as well as the year and model of motor-cycle in question.

CONTENTS

	<i>Section</i>	<i>Page</i>
GENERAL DATA	GD ..	1 to 10
LUBRICATION	A ..	1 to 6
ENGINE	B ..	1 to 19
CARBURETTER	C ..	1 to 8
FRAME AND FITTINGS	D ..	1 to 12
FRONT FORKS	E ..	1 to 9
WHEELS, BRAKES AND TYRES	F ..	1 to 12
ELECTRICAL EQUIPMENT	G ..	1 to 15
CHAINS	H ..	1 to 3
TORQUE WRENCH SETTINGS	J ..	1
SERVICING TOOLS	K ..	1 to 4
CONVERSION TABLES	L ..	1 to 10