

BSA SERVICE SHEET No. 516

Nov. 1959

Reprinted Nov. 1965

MODEL D7

FRONT FORKS AND STEERING HEAD

Remove the front wheel and mudguard as described in Service Sheet No. 515.

Prise out the top cap (A) Fig. D33 and unscrew the $\frac{3}{8}$ in. nut holding the top spring scroll.

Place a suitable tin underneath the fork end, take out the drain plug (B) and slacken the pinch bolt (C) in the bottom fork yoke.

To release the main tube from the taper in the top yoke pull the lower sliding member out to its fullest extent, unscrew and take out the top nut and screw in Service Tool No. 61-3350. Give the end of the tool a sharp blow with a hammer and draw the leg down through the bottom yoke.

Repeat for the other leg.

Place each leg in turn in a vice, gripping it on the flats of the fork end and unscrew the oil seal holder with Service Tool No. 61-3633.

The main tube can now be drawn upwards from the sliding member complete with the two bearing bushes, leaving the restrictor rod and spring still attached to the lower member. These need not be disturbed unless they are to be replaced.

Replacing Bushes

The lower bush is a press fit on to the main tube and the replacement must be fitted with the chamfered holes in line with the holes in the tube.

To remove the old bush, prise open the joint in the bush with a thin chisel or screwdriver and then tap the bush off.

The upper bush is a push fit in the lower sliding member and is retained in place by a washer and the top oil seal holder.

No difficulty will be experienced in replacing the top bush.

Reassembly

After fitting the new lower bush, slide the upper bush over the main tube with the flange uppermost, and apply a light coating of oil. Pass the tube over the spring and restrictor rod and slide into the lower member.

Holding the assembly in the vice by the fork ends, place the large washer in position over the flange on the top bush and screw on the oil seal holder with Service Tool No. 61-3633.

Take the assembly out of the vice and pass it up through the bottom fork yoke, place the top washer in position then screw on the large top nut and secure over the stud of the spring scroll.

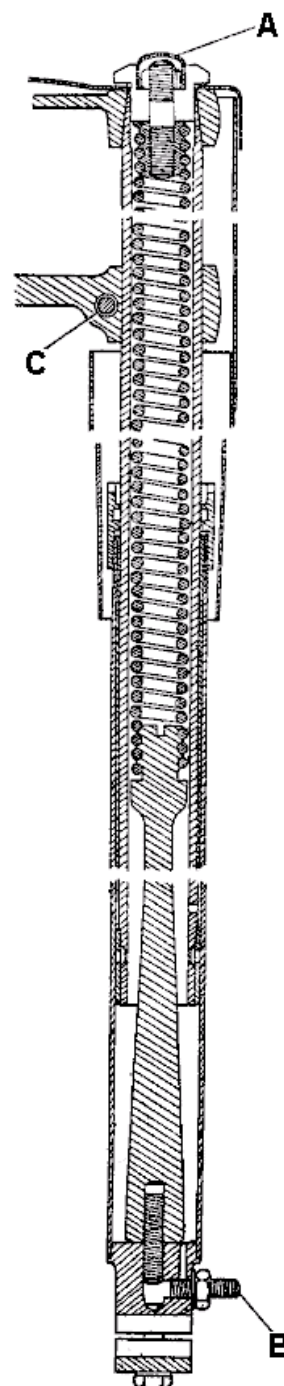

Fig. D33.
Front Fork Section

B.S.A. Service Sheet No. 516 (contd.)

The $\frac{3}{8}$ in. nut can now be refitted together with the top cap. Repeat the operation for the other leg.

Finally replace the mudguard and front wheel.

Steering Head

To adjust the steering head bearings place a weight on the saddle so that the front wheel is clear of the ground when the machine is on its stand.

Slacken the pinch bolt (A) Fig. D34 and adjust the nut (B) until the forks move freely from side to side without evidence of play in the bearings.

Take great care not to over tighten the nut (B) as this is liable to indent the bearings in the races.

When the adjustment is correct tighten the pinch bolt (A) securely and recheck the adjustment.

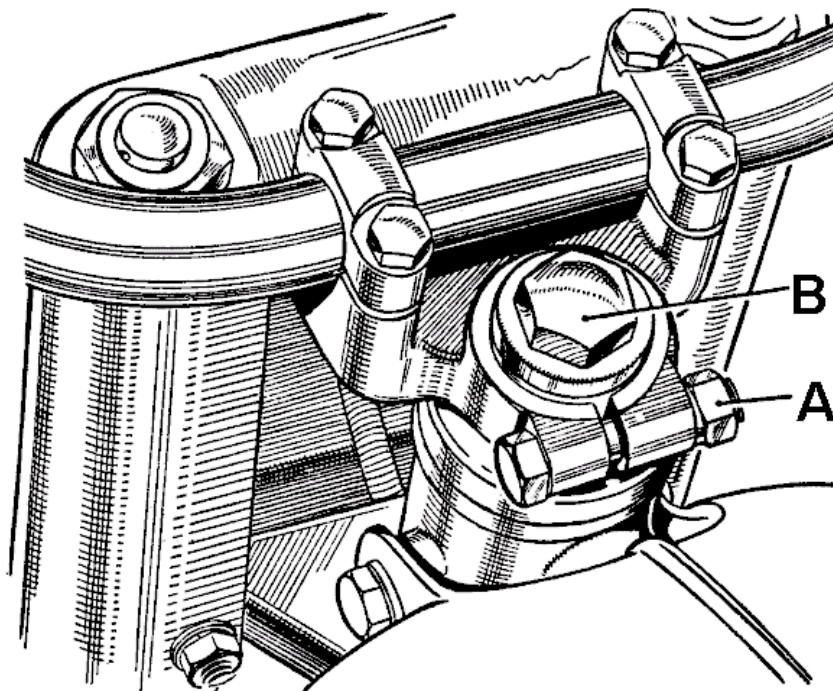

*Model D7. Front Fork and steering head.
Fig. D34.*

Dismantle the Steering Head

If the only attention required is examination or replacement of the head bearings there is no need to dismantle the forks completely, but the lighting cables to the headlamp will have to be broken at the couplings or sufficient slack obtained to move the forks away from the frame.

Remove the top caps from the forks, unscrew the $\frac{3}{8}$ in. nut and the large nut holding the main tubes.

Slacken the pinch bolt (A) Fig. D34 and take off the nut (B).

Undo the four bolts holding the handlebar clips, place a piece of cloth on the tank, remove the handlebar from the clips and lay it on the cloth.

Take off the top yoke cover, support the forks underneath and remove the top yoke by striking alternately each side underneath the handlebar clips.

After the top yoke has been removed, the steering column and forks can be drawn out of the frame but a suitable tray or container should be held underneath the column to catch the ball bearings which will be released.

B.S.A. Service Sheet No. 516 (contd.)

The cups, cones and balls should be clean and free from indentations or pitting. The top and bottom cups are identical, Part No. 65-4465, the bottom cone or crown race is Part No. 40-5027, and the top cone is Part No. 65-5319.

If new cups are fitted care must be taken to see that they are seated well down and square with the housing.

Reassembly

Apply a coating of grease to the steering head cups and insert 24 balls, 3/16 in. dia. in each cup.

Slide the column up through the steering head tube, being careful not to displace the balls, place the top cone in position, then the top yoke, and screw on the nut (B) Fig. D34.

Replace the top yoke cover, the $\frac{3}{8}$ in. nuts and the large nuts and washers and the handlebar, adjusting the steering head as previously described.

Finally recouple the headlamp wiring and check the lighting.